

Konsole Nr.:1 M1:10

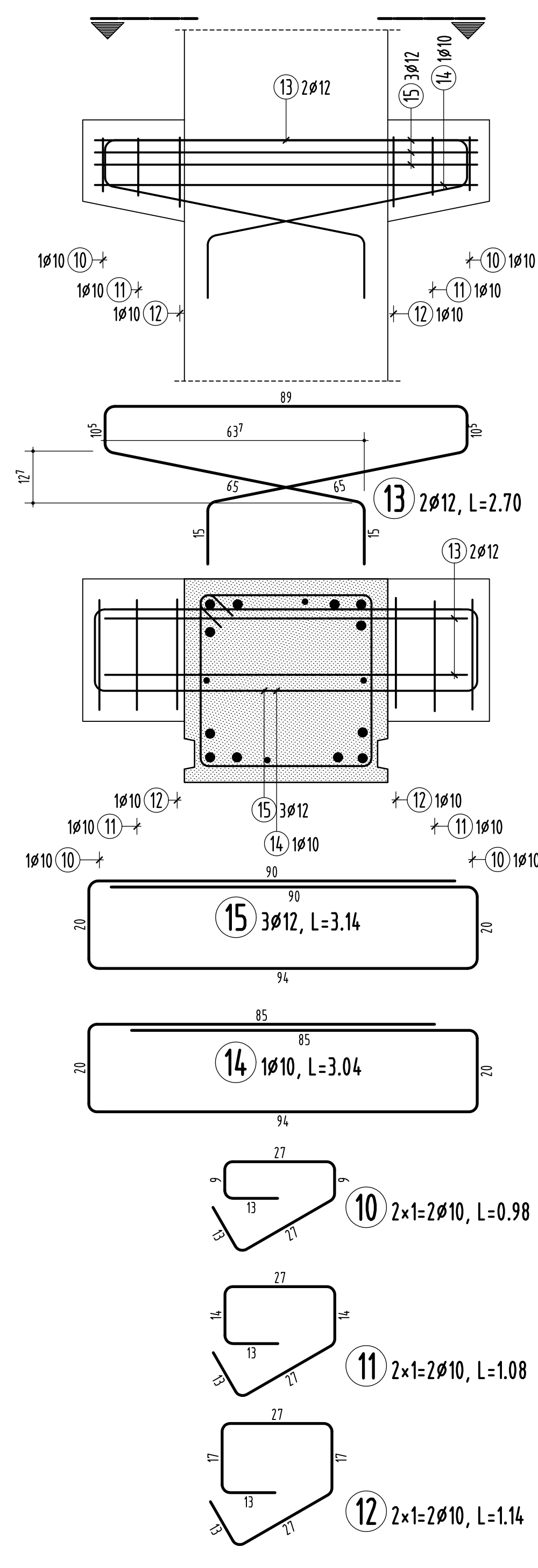

BEWEHRUNG SCHALUNG

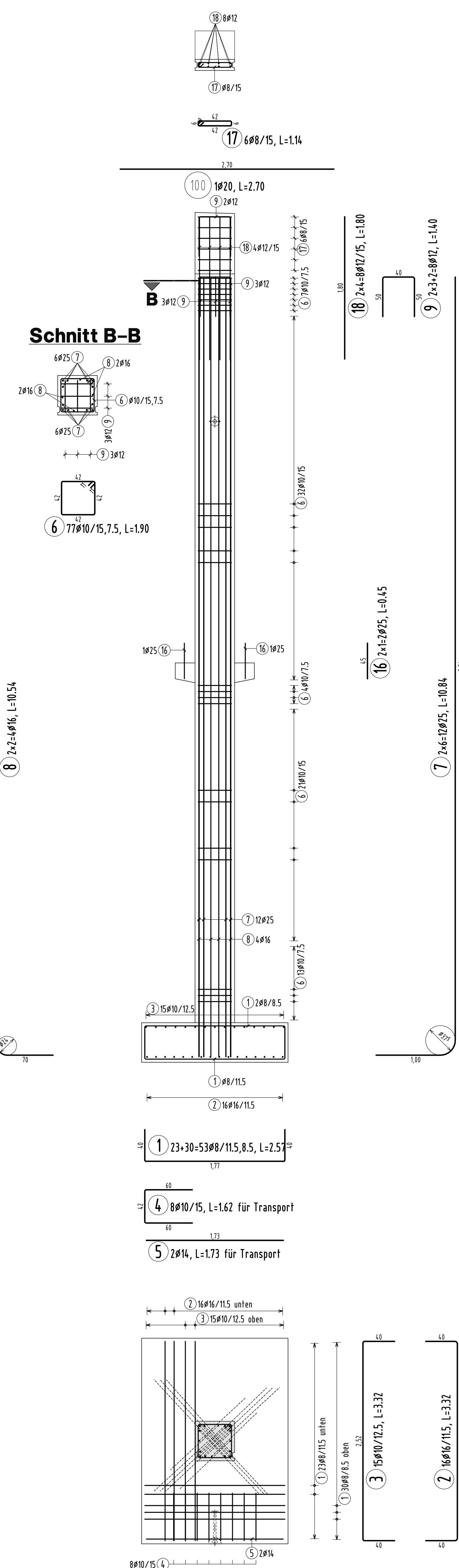

Seitenansicht

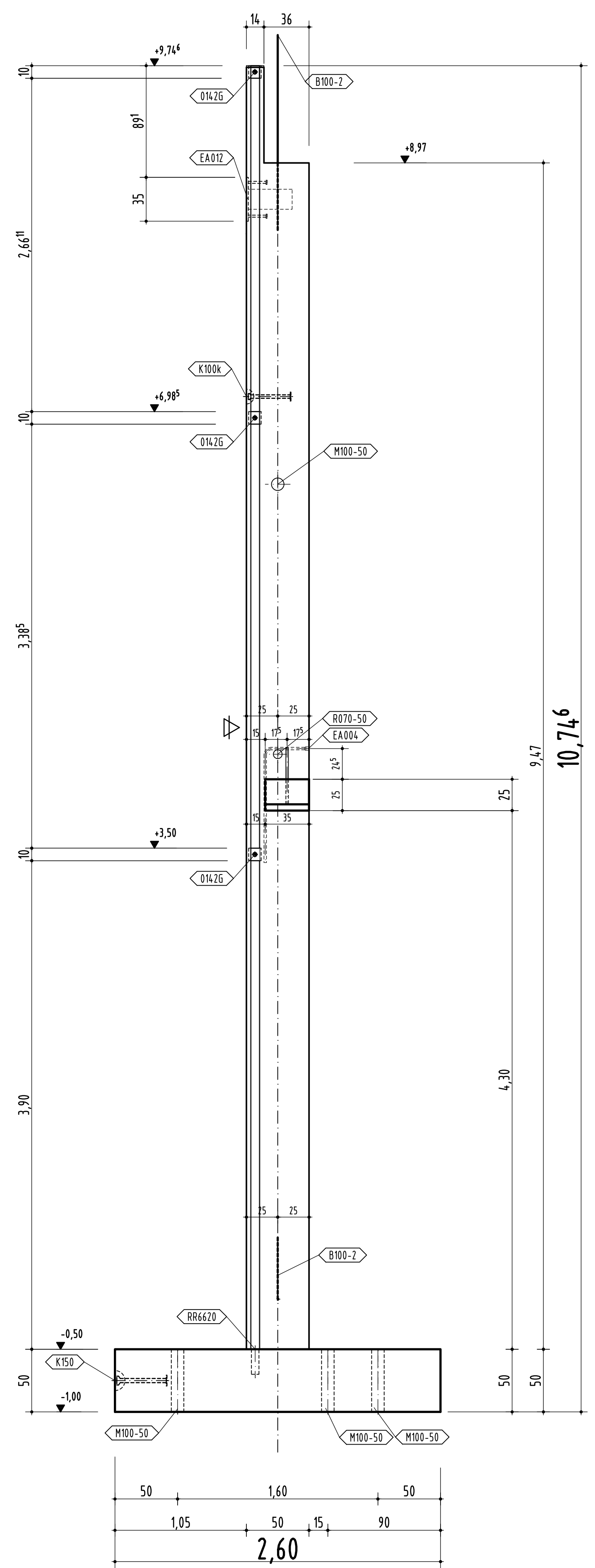

Draufsicht

Ansicht

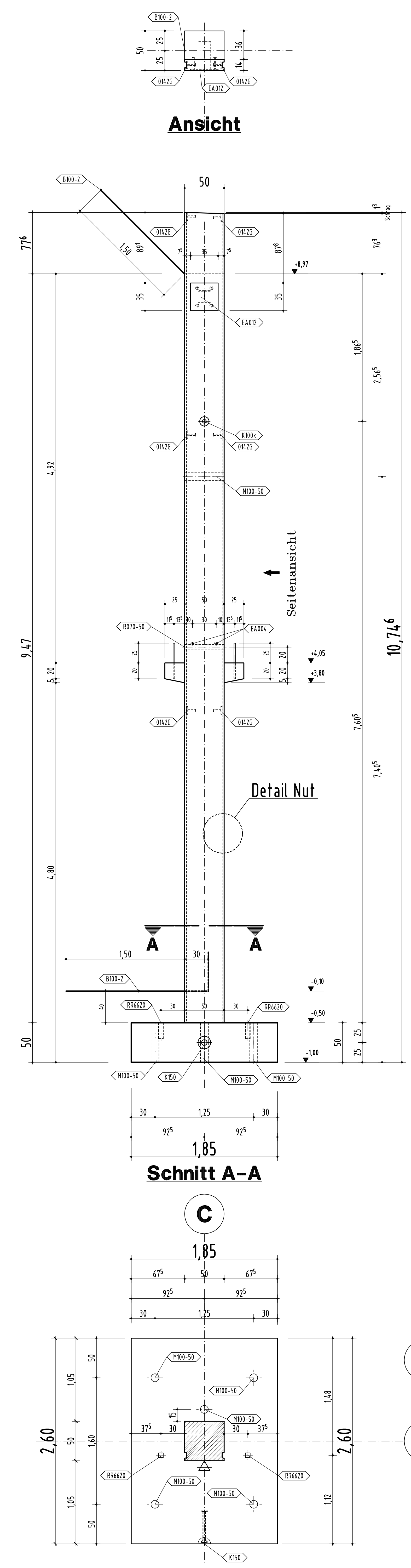

BETON: C45/55

Pos.	Stück	Bezeichnung
B100-2	1	Blittschutz Ø=10mm L=1,80m, verz.
K150	1	UEFH Kugelkopfanker 15 l. 400mm
M100-50	6	Montagebohrer i.Li. 100mm, L=50cm
R070-50	1	Kunststoffrohr i.Li. 70mm, L=50cm
01425	6	Stahlplatte 100/100/15mm, INB D=10mm, G=1,38kg, gestr.
E9004	2	PH-MB 20, a=36cm, b=52cm (05.322.202)
E9012	1	PH-50-50x25, MB 150, Lieferung GBE (P.78608)
K100K	1	UEFH Kugelkopfanker 10 l. 34cm
Z9003	2	PH-A 20 L=128cm (05.321.202.128)
R6620	2	Rechteckrohr 60/60 mm, L=200mm (Tasse), G=1,03kg roh

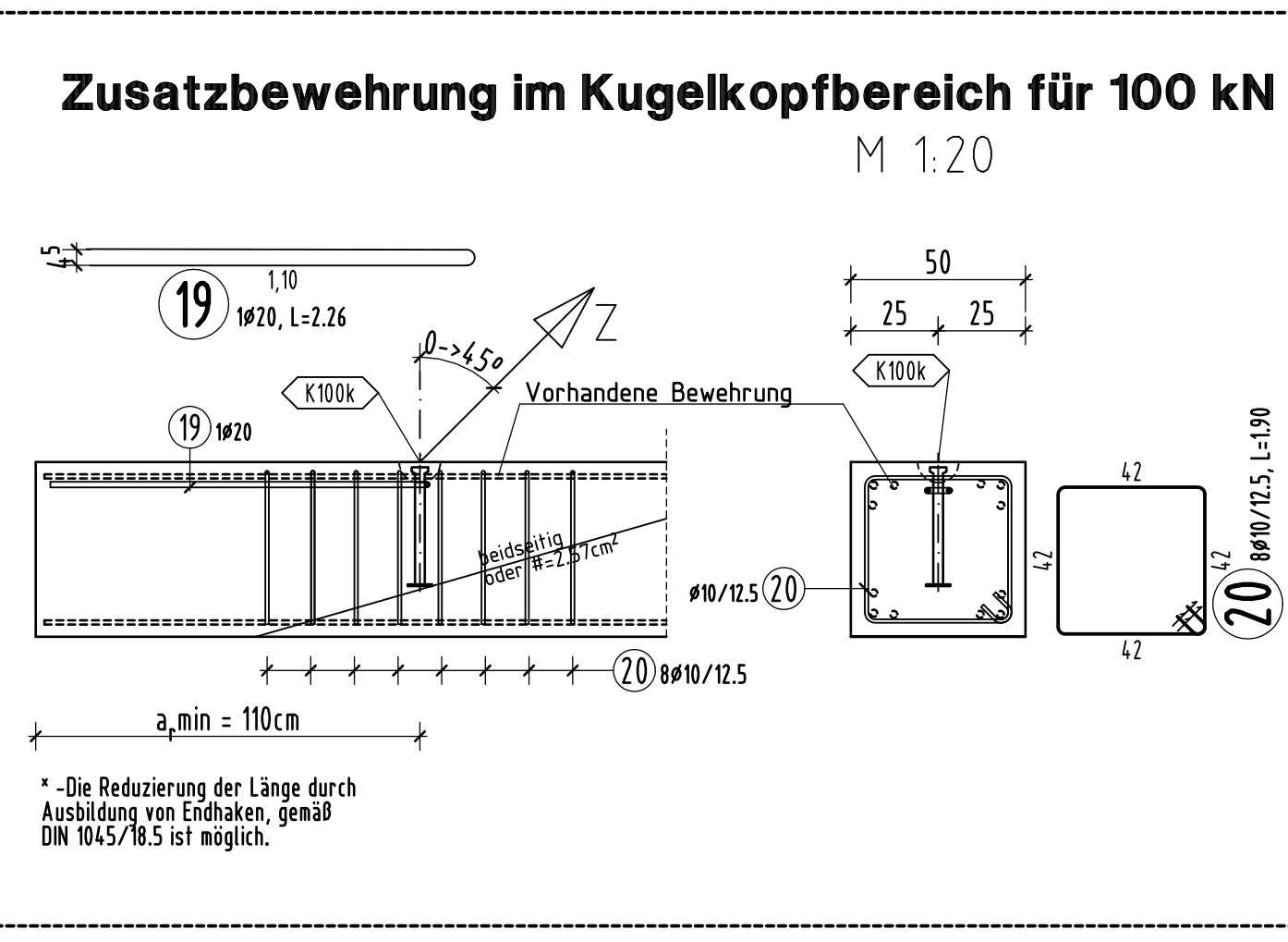

BETONDECKUNG

Fundament : 4.0cm
Exp. XC2, XF1
Stütze : 4.0cm
Exp. XF1